

Henri ALGADAFE

Un Long Chemin Sinueux

(2021)

Pour shakuhachi 2.4 en La et électronique

Notes

La partition est écrite en sons transposés, les hauteurs sonnent une quarte en-dessous.

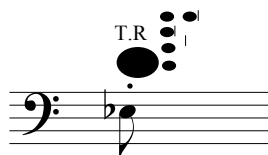

Jeu "tongue-ram". Le doigté indiqué doit produire la note écrite une quarte en dessous
Play a tongue ram. The concert pitch sounds a fourth below the written note.



Son bruiteux à hauteur indéterminé (Air seul).
Noisy and unpitched air sound blown in the tube



Sons à hauteurs définies, avec beaucoup d'air.
Pitched sounds with air

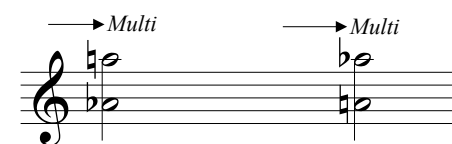

Progressivement vers des sons multiphoniques



38 : Les chiffres entourés situés au-dessus de la portée correspondent aux points de déclenchements d'évènements informatiques.

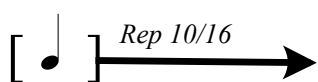

: Indique qu'une pulsation à la noire est jouée (dispositif informatique), et qu'il faut patienter de 10 à 16 temps avant de jouer la suite. Ces indications apparaissent en relation avec des points d'orgues de la partie instrumentale.

Section facultative avant l'enchaînement de l'évènement 32 de la partition

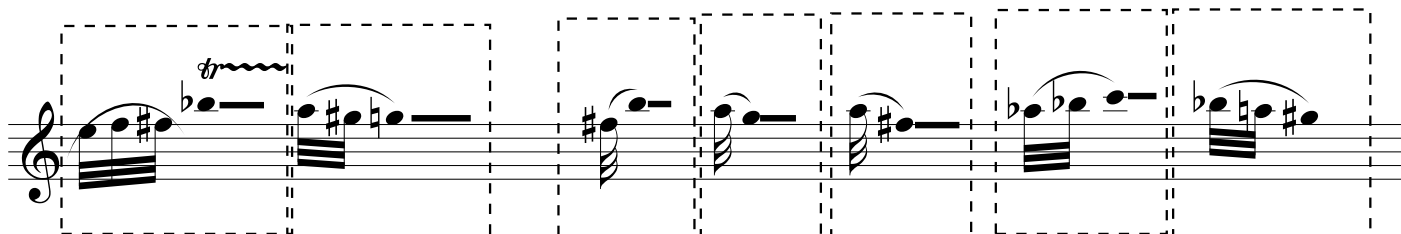

Après avoir joué les phrases correspondantes aux chiffres 30 et 31 de la partition, l'interprète peut décider, avant le déclenchement de 32, de rejouer brièvement et librement les cellules mélodiques ici décomposées, ainsi de prolonger la texture sonore. Elles seront permutées, sans être nécessairement toutes rejouées, éventuellement doublées, ou ornées de trilles.

Dispositif informatique

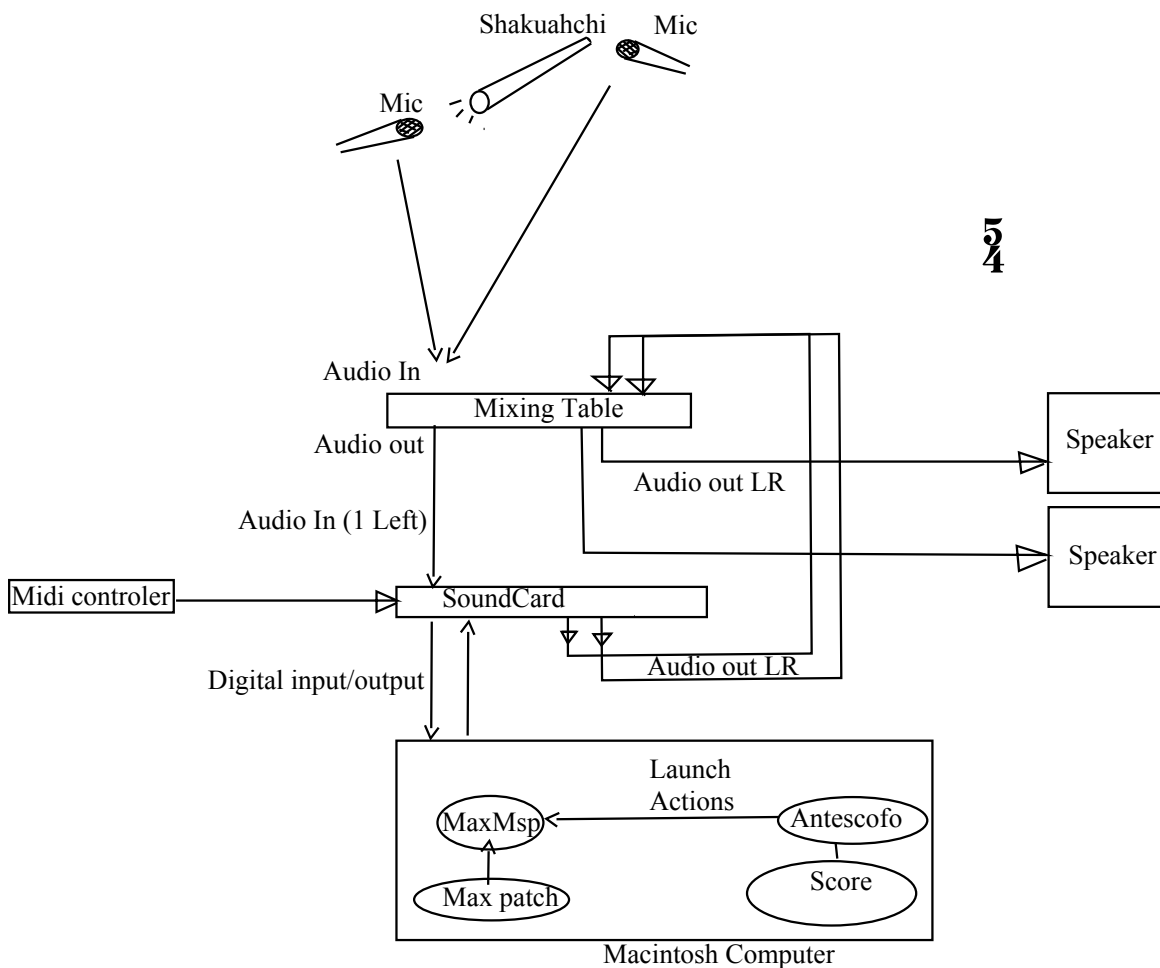

5
4

Deux micros captent le son de flûte. L'un est dirigé vers l'embouchure, l'autre vers le pavillon destiné au mode de jeu "tongue-ram". Ces deux sources sont mixées et envoyées à l'entrée gauche (1) de la carte son. Cette dernière est connectée à l'ordinateur dans lequel doit être installé le patch MAX correspondant à cette pièce. Les sorties stéréo de la carte son sont renvoyées dans la table de mixage puis aux enceintes de diffusion.

Le signal direct de la flûte ne doit pas être routé vers les sorties de la table. Les déclenchements nécessaires aux interactions avec le dispositif informatique se réalisent manuellement par contrôleur Midi, barre d'espace sur le clavier, ou messages "Program Change" Midi. La sélection se réalise sur la fenêtre principale du patch.

Les chiffres entourés situés au-dessus de la portée correspondent aux points de déclenchements d'événements informatiques.

Les informations indispensables à la gestion des actions programmées se retrouvent sur le fichier "UnLongCheminSinueux.asco.txt" qui est le "score" utilisé par l'application Antescofo présente dans le patch MAX

Pour Emmanuelle Rouaud,

Un long chemin sinueux...

Pour shakuhachi 2.4 et
dispositif informatique

Henri ALGADAFE

♩ = 42

A

The musical score is written in treble clef and consists of 24 numbered measures. The tempo is marked as ♩ = 42. The score includes various musical notations such as dynamics (p, mp, mf, f, pp), articulation (accents, slurs, trills), and performance techniques (Shake, Gliss 1/4, Vib, M, T.R., Meri). Measure 1 is marked with a circled '1' and a circled '1a' above it. Measure 4 has a circled '4' and a trapezoidal graphic above it. Measure 8 has a circled '8' and a trapezoidal graphic above it. Measure 17 has a circled '17' and a trapezoidal graphic above it. Measure 23 has a circled '23b' above it. The score is divided into systems of five measures each, with the final system containing measures 22, 23, and 24.

25 26 27

3

3

3

p

mf

28 29

3

9

5

3

ff

p

30 31 31b

3

3

3

3

mf

Section ad lib
avant 32.
Voir Notice

32 33 34 35 36

9

3

3

3

3

5

mf

f

37 38

9

9

mp

f

39 40 41 42

Komi buki

3

9

6

3

10

9

3

mf

43 44 45

3

3

3

9

3

f

mp

f

ff

46

3

mf

f

Komi buki

47 *mp* *f* 48 *p* *gliss* 49 *mf*

50 *mp* *gliss* *Rep 10/16*

51 *mf* *gliss* *mf* *pp* *f* *ppp*

52 *mf* 53 *p* *mf* *p*

55 *sfz* *mf* 56 *f* 57 *mp* 58 *p*

59 *Multi* *ff* 60 *p* 61 *Env 10 s* *sfz* *mp* *Gliss*

62 *mf* *Gliss* 63 *f* *p* *mf* 64 *Rep 8/14*

81 *mf* *tr* **65** *f* **66** *f* *Rep 6/10*

86 **67** *Gliss* **68** *f* *Rep 6/10* *Rep 4/8*

69 *Multi* **70** *Env 8s* **71** *f* *Rep 6/10* **71b** *p* *Gliss* *tr*

96 **72** *tr*

73 *gliss* **74** *mp* **75** *f* *tr* *3* *3*

76 *f* **77** *mp* **78** *Gliss* *3*

113 *p* *5:6* *mf* **79** *karakara* *gliss* **80** *f* *pp* *Rep 6/10*

118 **81** **82** M

p Soutenu *Gliss* *Gliss* *Rep 4/6* *f*

Detailed description: This musical staff covers measures 118 to 122. It begins with a treble clef and a 4/4 time signature. The first measure (118) contains a half note G4 with a 'p' dynamic and 'Soutenu' marking. The second measure (119) has a quarter note A4 with a 'Gliss' marking. The third measure (120) has a quarter note B4 with a 'Gliss' marking. The fourth measure (121) has a quarter rest followed by a quarter note C5 with a 'p' dynamic. The fifth measure (122) has a quarter note B4 with a 'p' dynamic, followed by a repeat sign for 4/6 measures. A large black wedge-shaped dynamic marking labeled 'M' is positioned above the final measure.

123 **83** **84**

p *ppp* *mp*

Detailed description: This musical staff covers measures 123 to 127. It starts with a treble clef and a 2/4 time signature. Measure 123 is a whole rest. Measure 124 has a quarter note G4 with a 'p' dynamic. Measure 125 has a quarter note A4 with a 'p' dynamic. Measure 126 has a quarter note B4 with a 'p' dynamic. Measure 127 has a quarter note C5 with a 'p' dynamic. A large grey wedge-shaped dynamic marking labeled 'mp' is positioned below the final measure.

85 M **86** M **87** **88**

mf *ff* *f* *mp* *gliss*

Detailed description: This musical staff covers measures 128 to 134. It begins with a treble clef and a 4/4 time signature. Measure 128 has a quarter note G4 with a 'mf' dynamic. Measure 129 has a quarter note A4 with a 'ff' dynamic. Measure 130 has a quarter note B4 with a 'f' dynamic. Measure 131 has a quarter note C5 with a 'mp' dynamic. Measure 132 has a quarter note B4 with a 'mp' dynamic. Measure 133 has a quarter note A4 with a 'mp' dynamic. Measure 134 has a quarter note G4 with a 'gliss' marking. A large black wedge-shaped dynamic marking labeled 'M' is positioned above the first measure, and another smaller one is above the second measure.

135 *Tsuki yuri* **89** M

mf *p* *f* *mp* *Rep 4/6*

Detailed description: This musical staff covers measures 135 to 139. It starts with a treble clef and a 4/4 time signature. Measure 135 has a quarter note G4 with a 'mf' dynamic and a 'Tsuki yuri' marking. Measure 136 has a quarter note A4 with a 'mf' dynamic. Measure 137 has a quarter note B4 with a 'p' dynamic. Measure 138 has a quarter note C5 with a 'p' dynamic. Measure 139 has a quarter note B4 with a 'p' dynamic. A large black wedge-shaped dynamic marking labeled 'M' is positioned above the final measure. A repeat sign for 4/6 measures is at the end.

140 **90**

mf *p*

Detailed description: This musical staff covers measures 140 to 143. It begins with a treble clef and a 4/4 time signature. Measure 140 has a quarter note G4 with a 'mf' dynamic. Measure 141 has a quarter note A4 with a 'p' dynamic. Measure 142 has a quarter note B4 with a 'p' dynamic. Measure 143 has a quarter note C5 with a 'p' dynamic. A large black wedge-shaped dynamic marking labeled 'M' is positioned above the first measure.

91 M **92** **93**

f *p* *f* *sfz* *f* *f*

Detailed description: This musical staff covers measures 144 to 147. It starts with a treble clef and a 4/4 time signature. Measure 144 has a quarter note G4 with a 'f' dynamic. Measure 145 has a quarter note A4 with a 'p' dynamic. Measure 146 has a quarter note B4 with a 'f' dynamic. Measure 147 has a quarter note C5 with a 'sfz' dynamic. A large black wedge-shaped dynamic marking labeled 'M' is positioned above the first measure.

94 **95**

ff *mp* *Rep 6/10*

Detailed description: This musical staff covers measures 148 to 151. It begins with a treble clef and a 4/4 time signature. Measure 148 has a quarter note G4 with a 'ff' dynamic. Measure 149 has a quarter note A4 with a 'mp' dynamic. Measure 150 has a quarter note B4 with a 'mp' dynamic. Measure 151 has a quarter note C5 with a 'mp' dynamic. A large black wedge-shaped dynamic marking labeled 'M' is positioned above the first measure. A repeat sign for 6/10 measures is at the end.

96 *mf* *Gliss* *Gliss* *sfz* *f* *soutenu* *mp*

Musical staff 96-97. Measure 96 starts with a *mf* dynamic and a *Gliss* marking. A triplet of eighth notes is followed by a *sfz* dynamic. A five-measure phrase leads to measure 97, which is marked *soutenu* and *mp*. A bracketed musical notation with an arrow indicates a transition.

160 98 *Gliss* *Gliss* *sfz* *f* *mp*

Musical staff 98-99. Measure 98 features a *Gliss* marking and a triplet. Measure 99 is marked *sfz* and *f*, with a triplet of eighth notes. The staff concludes with a *mp* dynamic.

165 100 *f* *Env 10 s* 101 *sfz* *p* *Gliss*

Musical staff 100-101. Measure 100 is marked *f* and includes a triplet. A dashed line labeled *Env 10 s* spans across measures 100 and 101. Measure 101 is marked *sfz* and *p*, with a *Gliss* marking. Below the staff are two large, shaded, wedge-shaped diagrams labeled *Medium A* and *Low B*.

170 102 *Gliss* *Gliss* 103 *mp* *f* 104 *mp*

Musical staff 102-104. Measure 102 has a *Gliss* marking. Measure 103 is marked *mp* and *f*. Measure 104 is marked *mp*.

176 105 *M* *f* 106 *mp* 107 *4:3*

Musical staff 105-107. Measure 105 is marked *f* and includes a *M* marking. Measure 106 is marked *mp*. Measure 107 is marked *4:3*.

182 108 *p* *Gliss* *Gliss* *f* *mf*

Musical staff 108-110. Measure 108 is marked *p* and includes *Gliss* markings. Measure 109 is marked *f*. Measure 110 is marked *mf*.

187 109 110

Musical staff 109-110. Measure 109 is marked with a triplet. Measure 110 is marked with a triplet.

192

Musical staff 192: Treble clef, 4/4 time signature. Starts with a triplet of eighth notes, followed by a half note, a quarter note, and a quarter rest. Dynamics include *p*.

111

112

Yoko Yuri

Musical staff 111-112: Treble clef, 4/4 time signature. Staff 111 contains a triplet of eighth notes. Staff 112 contains a triplet of eighth notes and a wavy line labeled *Yoko Yuri*. Dynamics include *pp*.

♩ = 60

113

114

115

116

Musical staff 113-116: Treble clef, 6/4 time signature. Staff 113 starts with a half note and a quarter rest, marked *mf*. Staff 114 has a half note, marked *ppp*. Staff 115 has a half note, marked *mf*. Staff 116 has a half note, marked *ppp* and *f*. A large dynamic wedge spans across the bottom of the staff.

117

Yoko Yuri

118

119

Tsuki yuri

Musical staff 117-119: Treble clef, 5/4 time signature. Staff 117 has a half note with *gliss* markings, marked *ppp*. Staff 118 has a half note, marked *mf*. Staff 119 has a half note, marked *f*. A large dynamic wedge spans across the bottom of the staff.

120

Tsuki yuri

121

122

Musical staff 120-122: Treble clef, 4/4 time signature. Staff 120 has a half note, marked *f*. Staff 121 has a half note, marked *ff*. Staff 122 has a half note, marked *ppp*, *f*, and *mf*. A large dynamic wedge spans across the bottom of the staff.

123

124

125

Musical staff 123-125: Treble clef, 4/4 time signature. Staff 123 has a half note, marked *sfz p* and *f*. Staff 124 has a half note with a triplet of eighth notes, marked *p*. Staff 125 has a half note with a triplet of eighth notes, marked *f*. A large dynamic wedge spans across the bottom of the staff.

224

126

127

Musical staff 126-127: Treble clef, 6/4 time signature. Staff 126 has a half note with a triplet of eighth notes, marked *ppp* and *mp*. Staff 127 has a half note with a triplet of eighth notes, marked *mp*. A large dynamic wedge spans across the bottom of the staff. At the end of the staff, there is a bracketed eighth note followed by an arrow and "X5".

128 *p* *mf* *mp*

[*mf*] X3

130 *sfz* *p* *f* *mp*

132 *mf*

gliss

133 *mp*

Komi buki

134 *pp*

135

241

136

137 *mp* *f*

138 *Env 10 s* *mf* *p*

139 *Gliss* *Env 5 s* *mf* *mf* *mp*

140 *mf*

141 *mf*

142 *p* *f*

Yoko Yuri

Air

Fine
Durée 19' env